

ST. LUKE'S CLEAR LAKE HOSPITAL AND PARKING GARAGE ERP #4 PARKING GARAGE

200 Blossom Street Webster, Texas

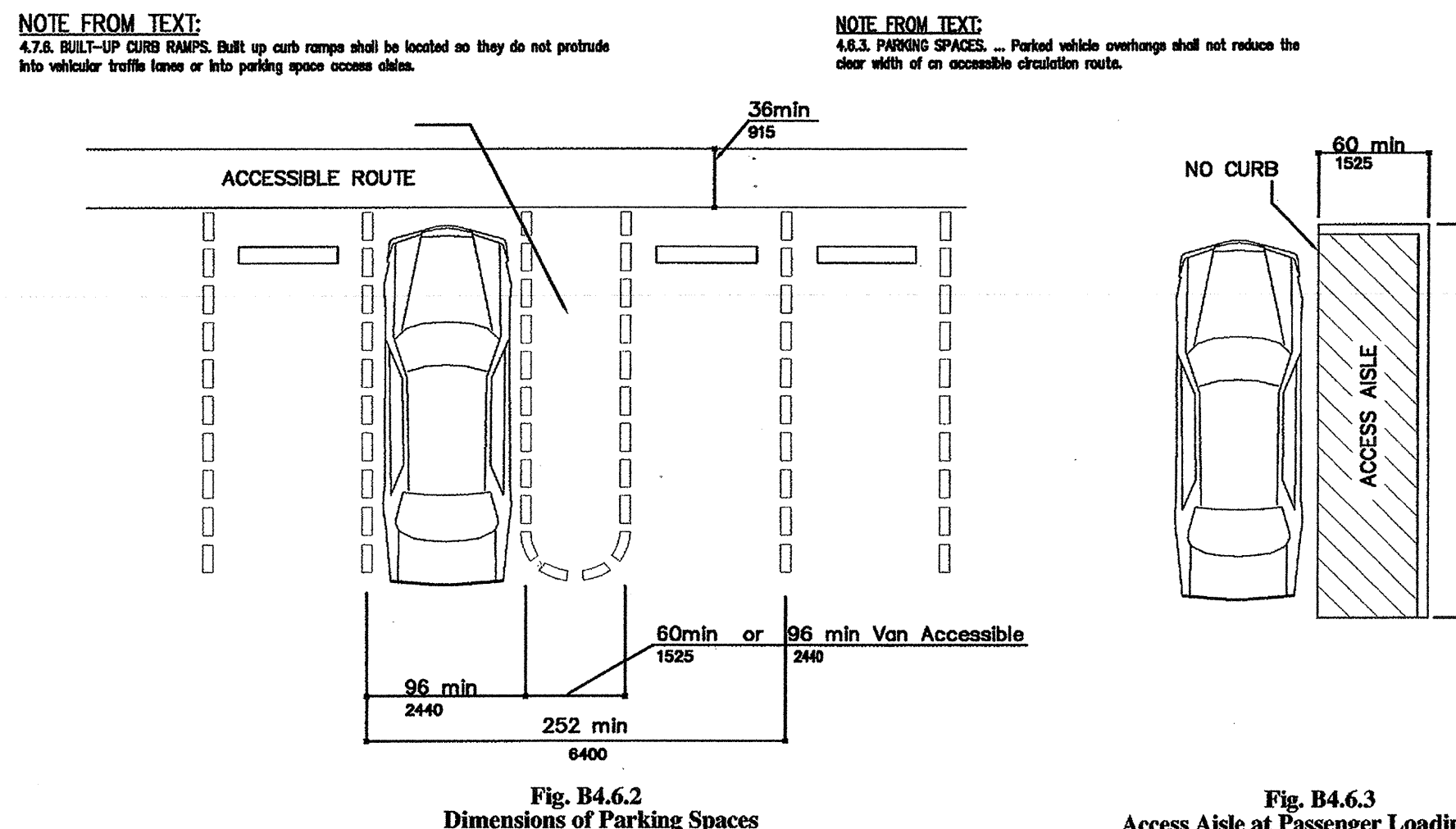
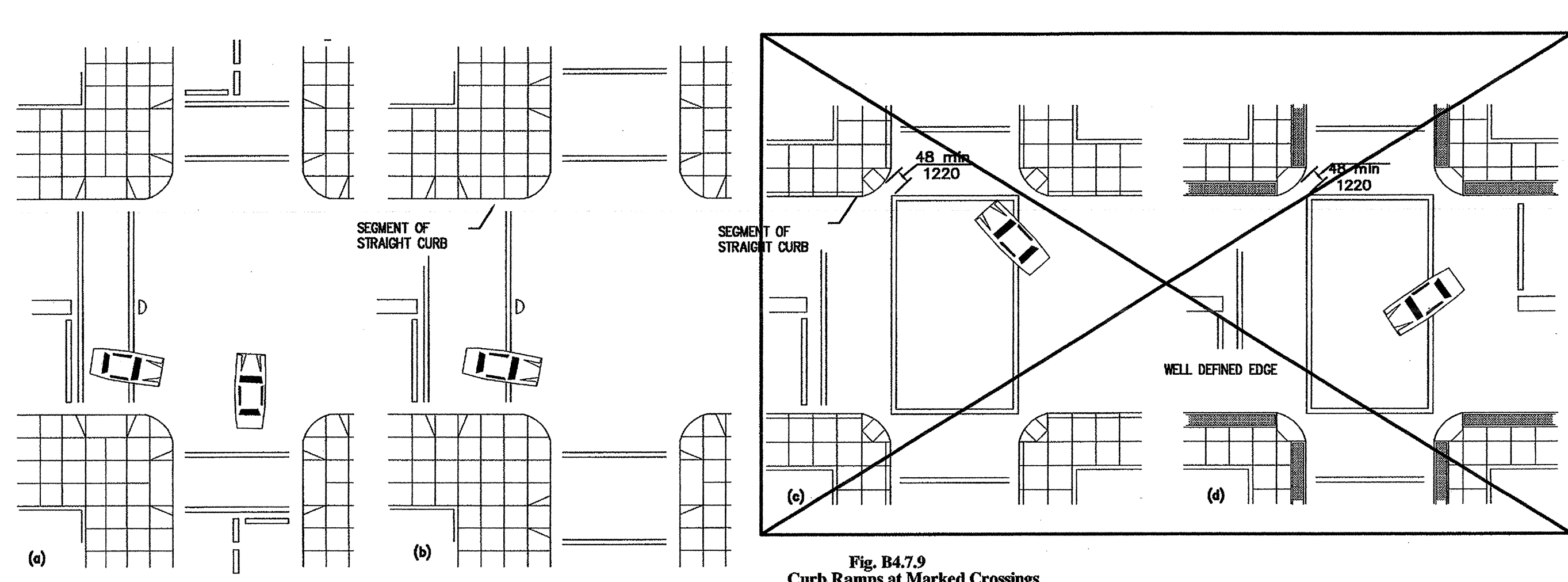

TOTAL PARKING SPACES IN LOT OR GARAGE	MINIMUM REQUIRED NUMBER OF ACCESSIBLE SPACES
1-25	1
26-50	2
51-75	3
76-100	4
101-150	5
151-200	6
201-300	7
301-400	8
401-500	9
501-1,000	2% of total spaces
OVER 1,000	20 spaces plus 1 space for every 100 spaces, or fraction thereof over 1,000

TABLE FOR THE FOLLOWING CODES SECTIONS:
1994 STANDARD BUILDING CODE T104.3, 1994 UNIFORM BUILDING CODE T11, TEXAS ACCESSIBILITY STANDARDS 54.1.2, 706.4.2, 2, AND 1995 AUSTIN LAND DEVELOPMENT CODE V2. S13-5-101.
VERIFY WITH LOCAL MUNICIPALITY ANY ADDITIONAL ORDINANCES, AMENDMENTS OR MODIFICATIONS.

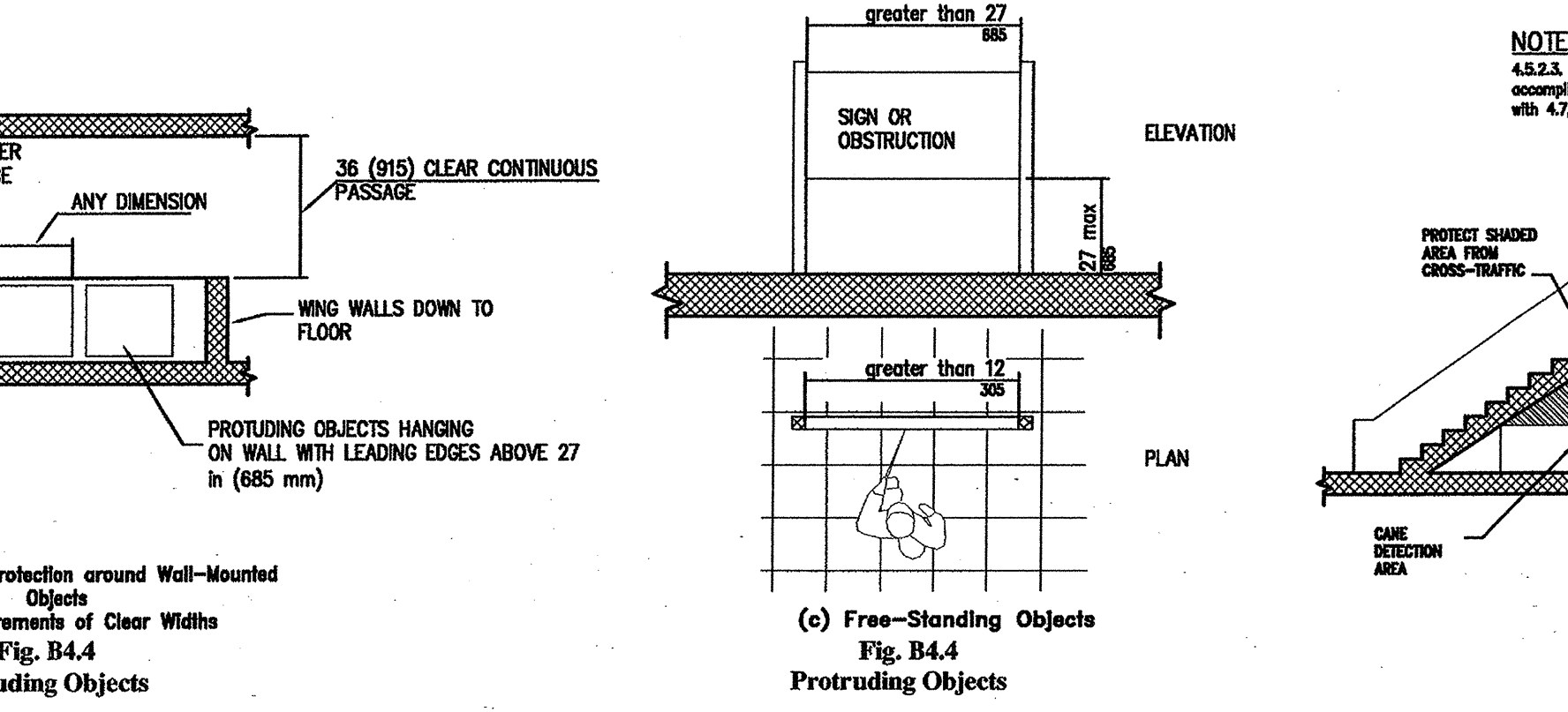
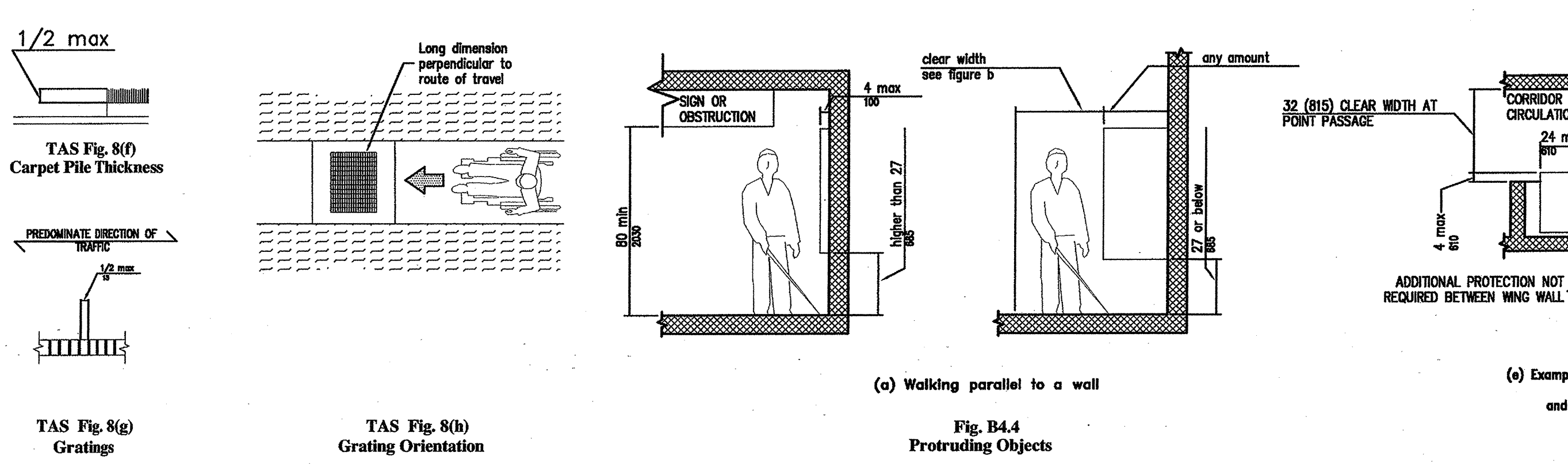

Slope	Maximum Rise	Maximum Horizontal Projection
1:12 to 1:15	30	760
1:16 to 1:19	30	760
1:20	30	760

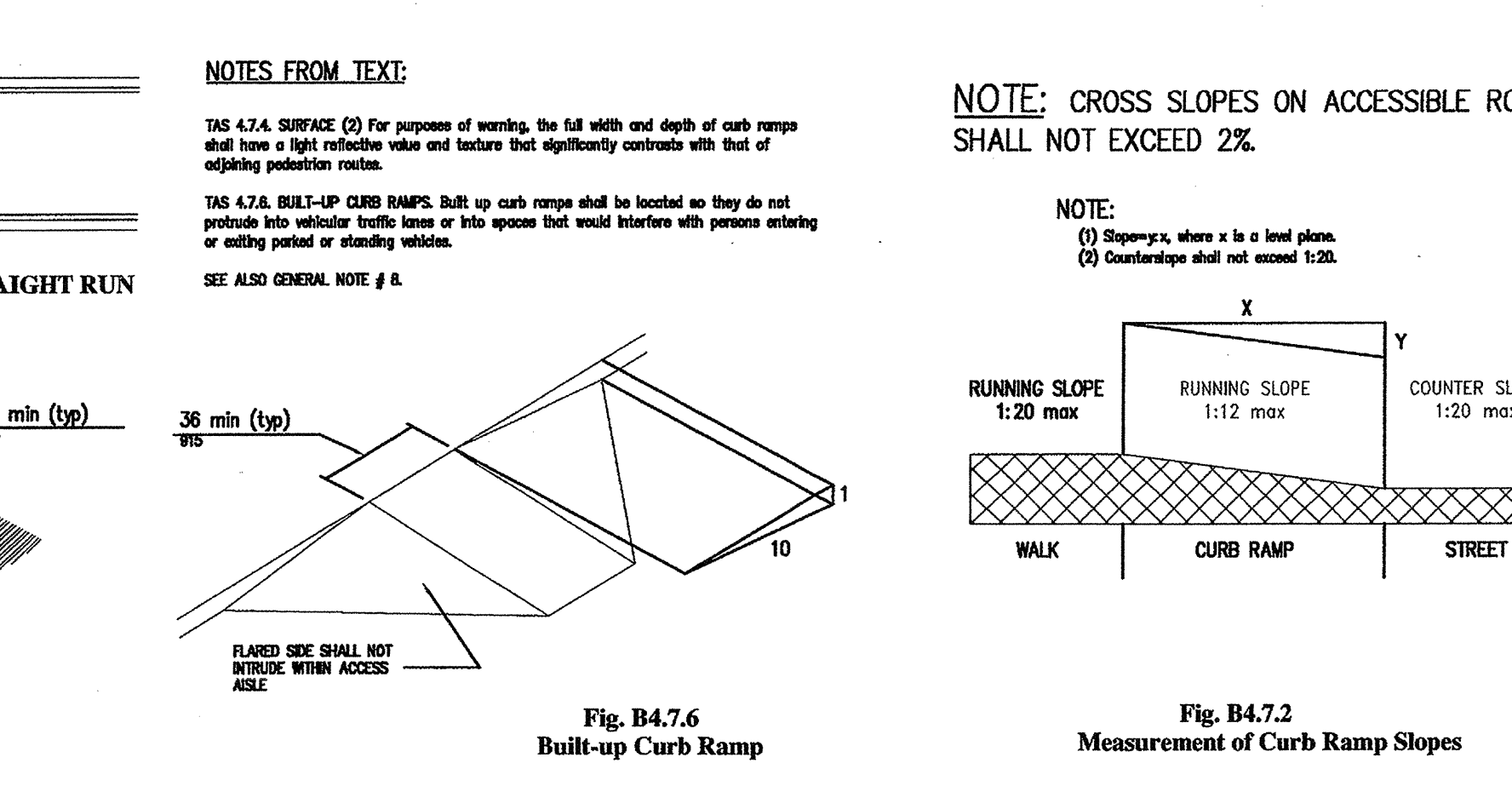
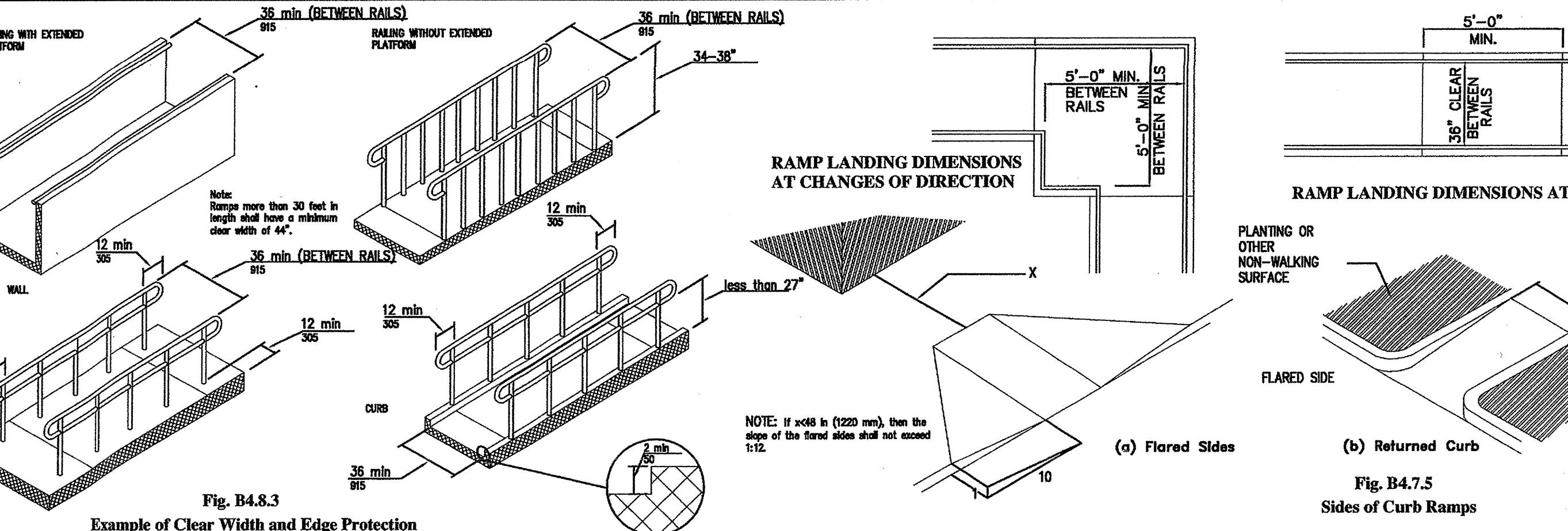

Slope	Maximum Rise	Maximum Horizontal Projection
1:12 to 1:15	30	760
1:16 to 1:19	30	760
1:20	30	760

